

Electrical and thermal simulation in the early design phase for electrical machines

Simulation-based Motor Design

Today’s development engineer faces many challenges.

Modern engines require high power density and high efficiency.

Different designs must be considered to be able to compete

on the market. Often time is essential and development cycles

are shortened or skipped. Simulation-driven Product Development

is the only way to guarantee the best quality.

Motor-CAD is one of the most complete electrical and thermal design software on the market for rotating electrical machines. With its three integrated modules – EMag, Therm and Lab – Motor-CAD enables motor designers to quickly and easily perform electromagnetic and thermal performance tests on many and varied machine topologies:

- **EMag** is a combined Finite Element (FE) and analytical based method for calculating electromagnetic and electrical performance on one operation point;
- **Therm** is mostly based on a 3D lumped circuit parameter thermal network approach automatically setup with user inputs;
- **Lab** is used to calculate performance of the machine across its full operating range, including efficiency maps, torque-speed curves, continuous thermal envelope and duty/drive cycle analysis.

The EMag, Therm and Lab modules can be used iteratively, allowing electrical machine designers to produce designs within specified electrical and thermal limits. In a typical “V” cycle workflow (Fig 1), Motor-CAD is particularly useful in the early stage of the machine development for initial design, topology selection, sizing, and optimization across the full operating envelope.

When associated with optiSLang software, Motor-CAD’s above-mentioned capabilities are combined with powerful op-

timization algorithms that allow to evaluate thousands of potential candidates in a computationally efficient way and select the best design with respect to the specification.

Motor-CAD is driven by optiSLang through the so-called ActiveX connection to define, control and extract parameters of interest. First a meta-model based sensitivity analysis is performed on the Motor-CAD model, where the design space is scattered with different combinations of input parameters. Then optiSLang builds the so-called Meta-model of Optimal Prognosis (MOP), that represents the most important correlation between input parameters and responses. An optimizer is finally applied to the MOP. The main advantages of this strategy are twofold:

Requirement	Value	Unit
Peak power	200	kW
Peak torque	370	Nm
Maximum speed	20000	rpm
Nominal torque @ 2krpm	152	Nm
Nominal power @ 20krpm	70	kW
Efficiency over WLTP3 cycle	≥ 94.5	%
DC bus voltage	≤ 720	V
RMS phase	≤ 500	A
Stator	≤ 250	mm
Machine	≤ 250	mm
Active	≤ 42	kg

Table 1: Motor requirements

1. It gives the designer an insight on where to concentrate the effort for a given optimization problem;
2. It provides results very quickly for different set of objectives and constraints.

This approach was used to design a 200 kW, 20 krpm copper rotor induction motor for an electrical vehicle. The main specifications are given in Table 1. The stator winding is of hairpin type and the rotor is either die-casted or fabricated. The cooling system consists of a conventional housing water jacket coupled with a spiral groove shaft cooling, using a mixture of ethylene, water and glycol as a coolant.

The machine was optimized electromagnetically according to the procedure described before, so as to find the best compromise between machine length (or machine cost) and efficiency over the WLTP3 drive cycle, while remaining within its limits in terms of volume, weight and performance. More than 10 thousand design configurations were evaluated within minutes using an evolutionary algorithm applied directly to the MOP.

Thermal envelopes of specific designs picked on the front were calculated afterwards, considering maximum temperature of 180°C in the rotor cage and the stator winding (Fig 2). The results show a real trade-off between efficiency (η), machine length (L), weight (W) and continuous performance. The design 160.8 mm long appears to be the most promising solution with respect to the specification. Its geometry is shown in Fig 3.

The study can be pushed further. The cooling system characteristics may be for instance included into the optimization loop. Also a local optimizer from optiSLang can be applied directly to the Motor-CAD system for more accurate results.

This being said, the topology obtained from the MOP-based optimization lays a strong and sufficient foundation for the latter stages of design. Motor-CAD can be coupled with ANSYS packages to be used alongside with 3D FEA and CFD tools for more detailed analysis. It is also very valuable to use during the motor test and validation process to identify any manufacturing issues with the machine and provide improved modelling for the next design iteration.

Acknowledgment

This project has received funding from the European Union’s Horizon 2020 Research and Innovation Programme under the Grant Agreement No 770143.

Fig. 1: A typical "V" cycle workflow

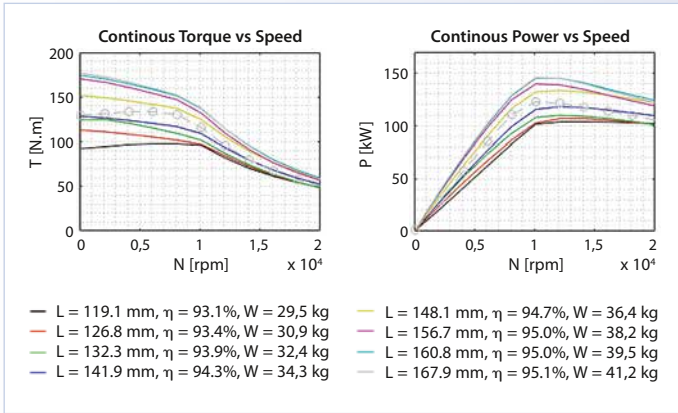
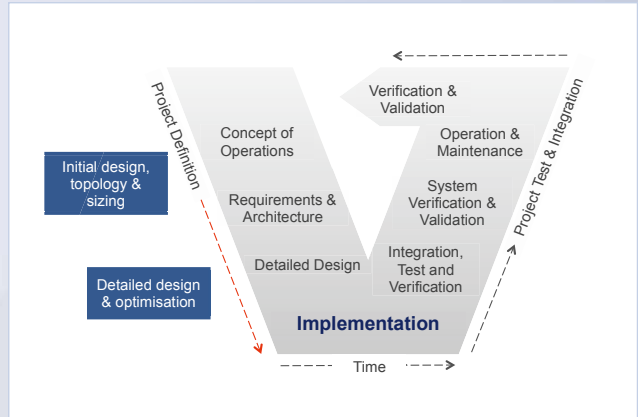

Fig. 2: Continuous performance of selected optimized designs

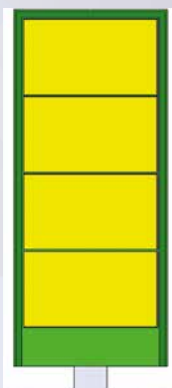
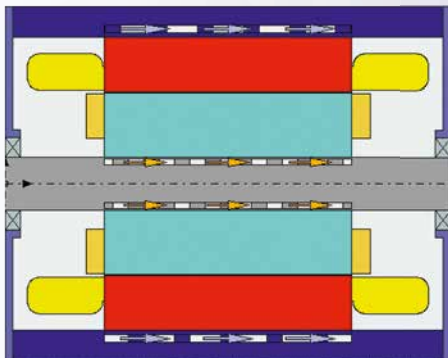
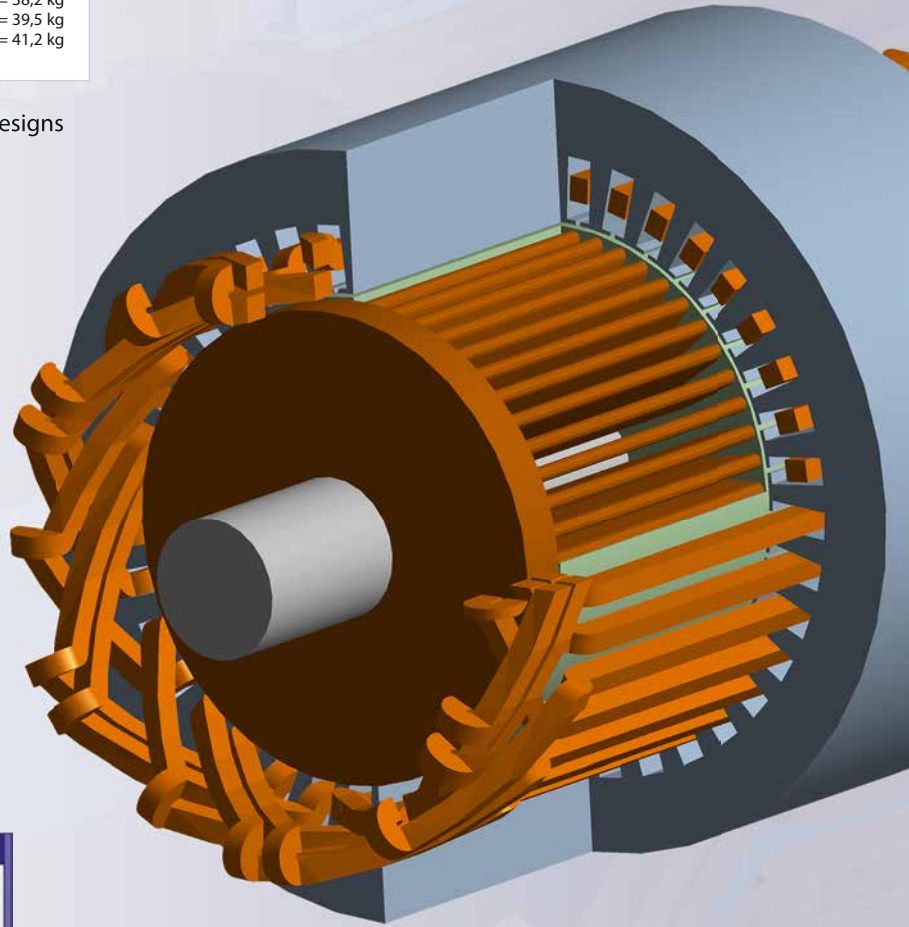
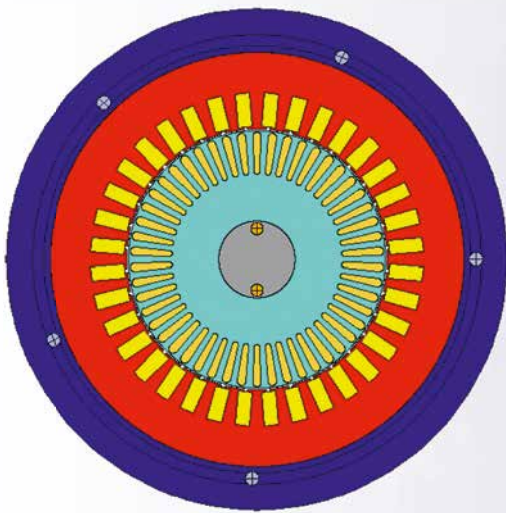

Fig. 3: Radial, axial and stator slot cross sections (Design n°10647)

InfoInternet
www.cadfer.net/motorcad

InfoContact | Motor-CAD
 Nicolas Rivière
 Tel. +44 (0)16 91-62 33 05
nicolas.riviere@motor-design.com
www.motor-design.com

InfoContact | CADFEM
 Philipp Siehr
 Tel. (0) 80 92-70 05-129
psiehr@cadfer.de
www.cadfer.net

InfoWebinar
www.cadfer.net/webinar-motorcad